

The sampling station EASYPOOL is a variable unit consisting of several individual components which are described in detail in the corresponding technical documentation. This documentation deals exclusively with the special features of the EASYPOOL sampling station. Therefore, please also observe the technical documentation of the individual components such as: TOPAX, chlorine measuring cell CS120, pH, Redox, temperature electrodes etc..

General

Swimming pool water disinfection predominantly occurs by means of chlorine in its various chemical compositions. The water sampling station EASYPOOL was especially developed for private swimming pools to monitor the hygienic parameters and to ensure the metering of the corresponding chemicals. In the highest configuration even hypochlorite metering, pH correction and flocculation agent metering is possible.

Water sampling and metering station EASYPOOL

EASYPOOL is offered in various configuration levels depending on the application. Please see also our price list, page 2 37 17.

For measuring the free effective chlorine the chlorine measuring cell CS120 or the REDOX electrode are available.

The sampling station EASYPOOL includes the following features:

- Trouble-free metering
Peristaltic pumps also deliver degassing media, such as sodium hypochlorite solution, and they are self-ventilating. Due to transparent pump heads optical function control is also possible.
- Optimum flocculation
The peristaltic pump EASYDOS is used for metering flocculation agents and is adjusted to the filtration process by means of the speed.
- Saving of water
The sampling water is lead back into the water system.
- The controller and measuring amplifier TOPAX Pool
- Minimum installation work required
The complete sampling, control and metering unit is premounted to a compact panel for wall mounting.
- Easy operation and maintenance
Transparent fittings for flow monitors, electrodes and filters offer a good view into the measuring



- devices.
- Optical and electronic function control.

Function

The measuring signals from the electrodes for free chlorine, pH, redox, temperature and flow rate are transmitted to the TOPAX Pool. There they are compared to the desired values. In the case of deviating values the corresponding pumps are activated and the chemicals are metered until the desired value is reached.

Technical data

Measuring range free chlorine	0-2ppm
Measuring range pH	pH 0 - pH 14
Measuring range redox	0-1000mV
Measuring range temperature	1°C - 40°C
Sampling water requirement	42 l/h
Water pressure	0.15 - 6 bar
Tubing connections	6/12 mm
Dimensions (H/W/D)	900x490x100 mm

Order numbers:

Redox and pH	23700212
Free chlorine and pH	23700210

For other configurations and prices, please see also our price list PL 2 37 17 / 1

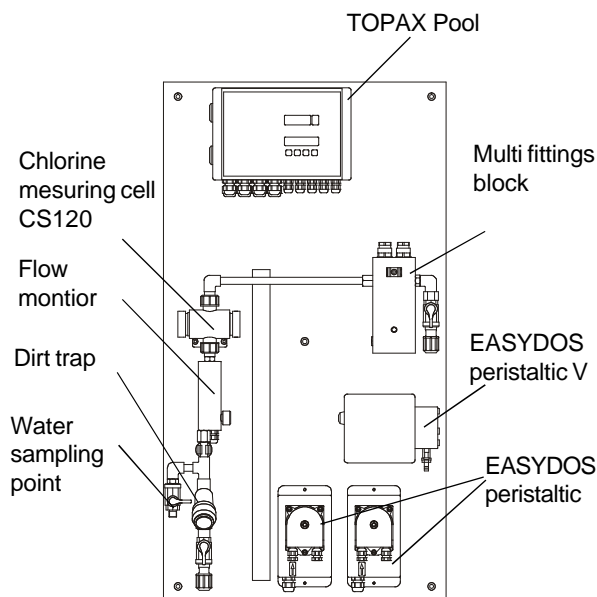

1. Tubing connection (=inlet)
2. Stop valve
3. Bevel-fit filter
4. Water sampling point
5. Adjustment screw
6. Flow monitor
7. Free chlorine measuring cell
8. Temperature electrode
9. Fitting for redox electrode
10. Fitting for pH electrode
11. Acrylic block for mounting pos. 8-10
12. Stop valve
13. Tubing connection (=outlet)

Scope of delivery

In the highest equipment configuration EASYPOOL is premounted to a plastic panel, wired and equipped with the following components :

- controller TOPAX POOL
- flow monitor for manual and electronic monitoring
- free chlorine measuring cell CS120 copper/platinum with self-cleaning electrode, alternatively redox
- acrylic block for mounting electrodes
- pH electrode
- temperature electrode
- peristaltic pump EASYDOS for sodium hypochlorite solution
- peristaltic pump EASYDOS for pH correction
- peristaltic pump EASYDOS Peristaltic V for flocculating agent

All you must do is to provide the sampling station with sampling water and supply voltage and to connect the chemical tanks to the suction side of the pumps.

The EASYPOOL delivery scope is very flexible. Therefore, please check our price list.

Accessories

With very dirty water, e.g. in an outside pool, we additionally recommend to use the 80µm sampling water filter with wall holder and clamping connections for tubing 6/12, order number 23733816.

Hydraulic system

The sampling water reaches the EASYPOOL sampling station through a tubing connected to it at the tubing connection (1). The bevel-fit filter (3) eliminates disturbing dirt particles from the sampling water. Using the adjustment screw (5), the correct sampling water flow is set which is controlled by means of the flow monitor (6) and supervised by the TOPAX Pool. Now the sampling water passes the free chlorine measuring cell (7) at an optimum flow. Then the sampling water reaches the acrylic block (11) to which the temperature, redox and pH electrodes (8, 9 and 10) can be mounted. The sampling water flows out of the EASYPOOL through the tubing connected to the tubing connection point (13). For calibrating the measuring cell CS120 a water sample can be taken at the sampling water point (4). By closing the stop valves (2 and 12) EASYPOOL can be depressurized in the case of maintenance and calibration work, e.g. for calibrating the pH and redox electrodes in buffer solutions.

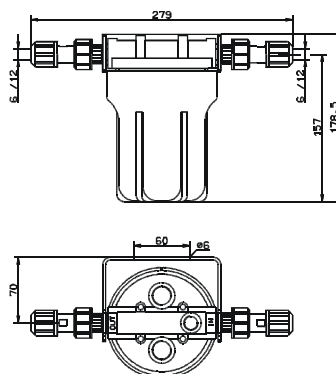
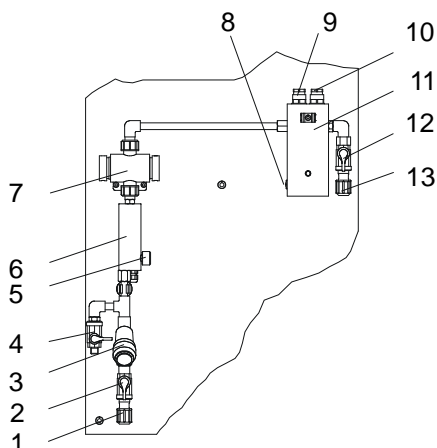

As suction line for containers we recommend to use our type SA .
Order number 12224451

For injection points, please cf. MB 1 23 01, as e.g.:
type S for 4/6 tubing with 1/4 " external thread,
order number 12327059.

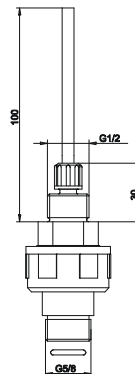
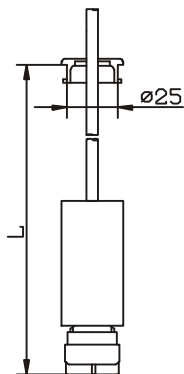

Installation example

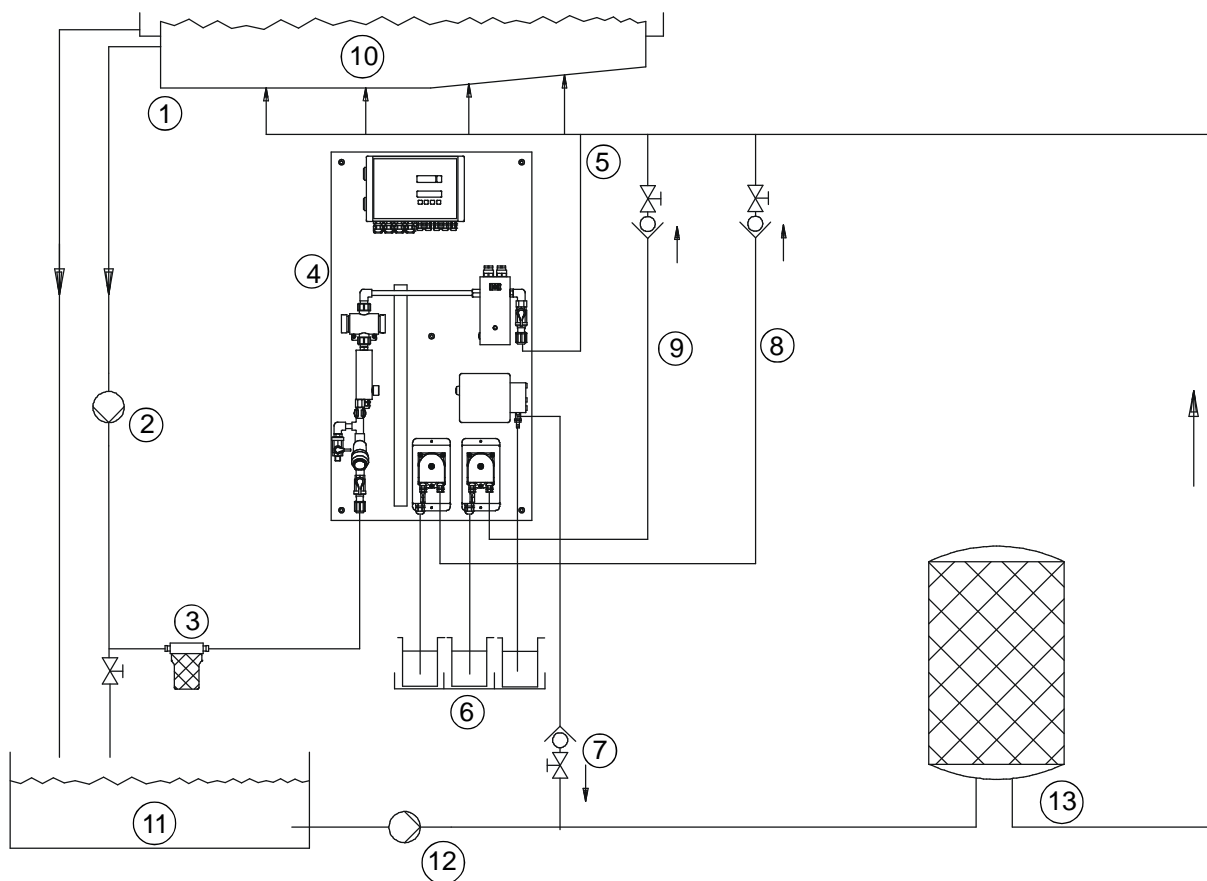

Legend

- | | |
|--------------------------------------|--|
| 1 Water sampling point | 8 Injection point pH control |
| 2 Sampling water pump | 9 Injection point sodium hypochlorite solution |
| 3 Sampling water pre-filter | 10 Swimming pool |
| 4 Sampling station EASYPOOL | 11 Splash water basin |
| 5 Sampling water recirculation | 12 Untreated water pump |
| 6 Chemicals supply + drip tray | 13 Filter unit |
| 7 Injection point flocculating agent | |

We would like to point out that the installation example is not obligatory.

General view

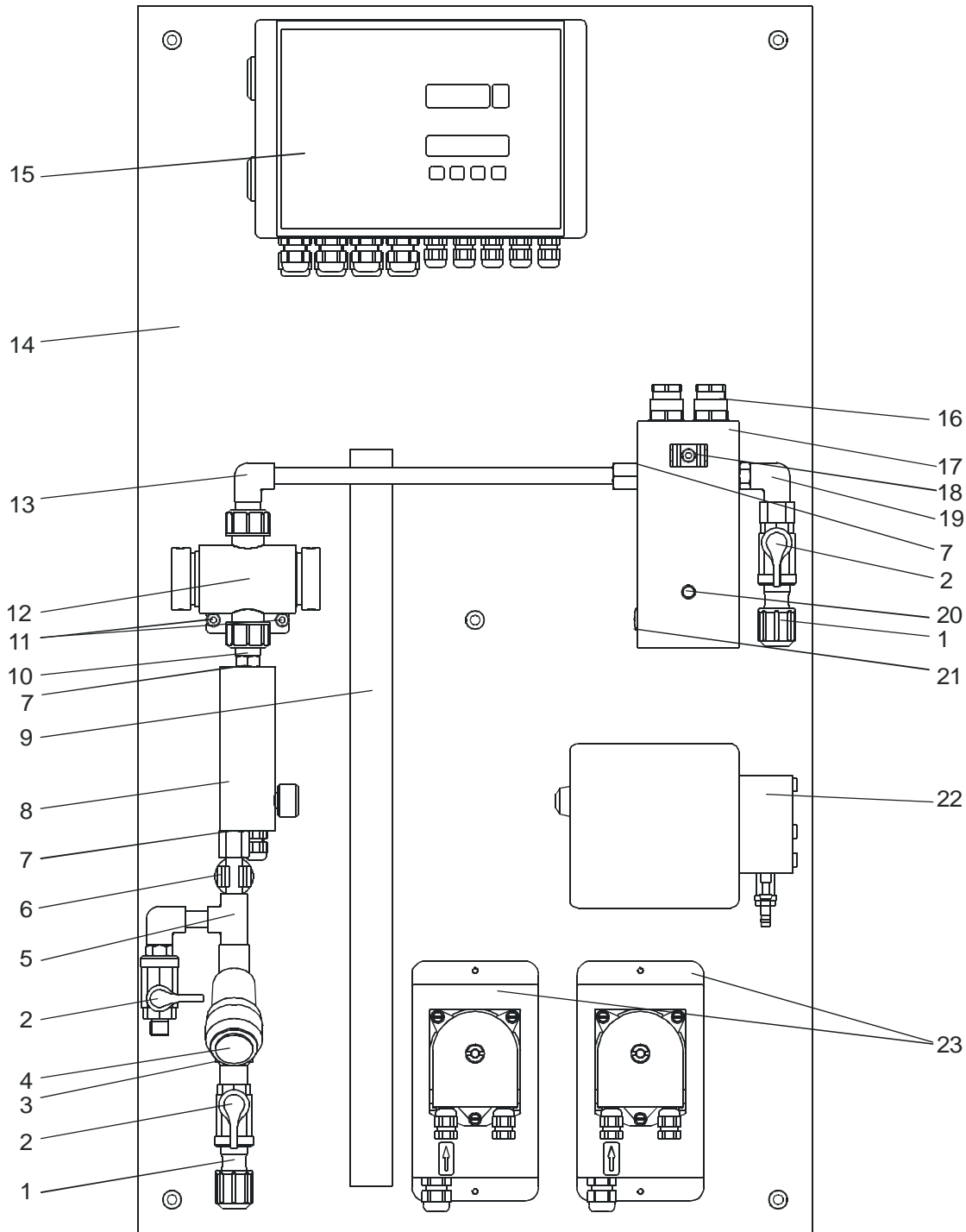

Water Sampling and Metering Station EASYPOOL

Spares list to general view

Pos.	Qty.	Designation	Order no.	Material/color/dimensions
1	2	Clamping connection for 6/12 tubing	26487	PVC, grey
2	3	Laboratory ball valve DN6	12434369	PVC, grey
3	1	Pipe clamp d16	22981	PE, black
	1	Spacer disc	28632	PVC, grey d28/5 x 16mm
	1	Cap screw	83482	VA, M4 x 25
4	1	Strainer insert	88093	PVC, beige
5	1	Preassembled strainer piping completely cemented incl. sealings	35551	PVC, grey and transparent
6	1	Pipe clamp d12	26840	PE
7	3	O-ring	80058	Viton 12x2
8	1	Flow monitor	s. foll. page	PMMA, transparent
9	1	Cable duct	77392	PP, grey 23x31 540mm lg
	4	Oval head screw	83457	Steel, galvanized 4.2 x 9.5 m
10	1	Connecting piece incl. sealings	35552	PVC
11	2	Cap screw	83608	M5 x 16
	2	Washer	84164	VA, d 5.3
12	1	Chlorine measuring cell CS120		see MB 4 10 00
13	1	Chlorine measuring cell preassembly Multi fittings block incl. sealings	35553	PVC, grey
14	1	Base plate	31778	PP, grey 900x490x10
15	1	TOPAX Pool		see MB 4 50 02
16	2	Union piece PG 13.5 or plug PG 13.5	33906	PA, black
			78883	PA, grey
	2	O-ring	80001	Viton 20.35 x 1.78
17	1	Multi fittings block	35964	PMMA, transparent
18	1	Pipe clamp d16	22981	PE, black
	1	Spacer disc	34213	PP, grey
	1	Cap screw	83756	VA, M5 x 65
19	1	Multi fittings block outlet piping incl. sealings	35554	PVC, grey
20	1	Spacer disc	34213	PP, grey
	1	Hexagonal screw	83689	VA, M5 x 55
	1	Washer	84164	VA d 5.3
21	1	Blanking plug	78235	PA, black M12 x 1.5
	1	O-ring	80058	Viton 12 x 2
22	1	EASYDOS-peristaltic V		see MB/ET/BW 1 10 02
23	2	EASYDOS-peristaltic		see MB/ET/BW 1 10 01
	1	Set of sealings	35555	div.

Flow monitor

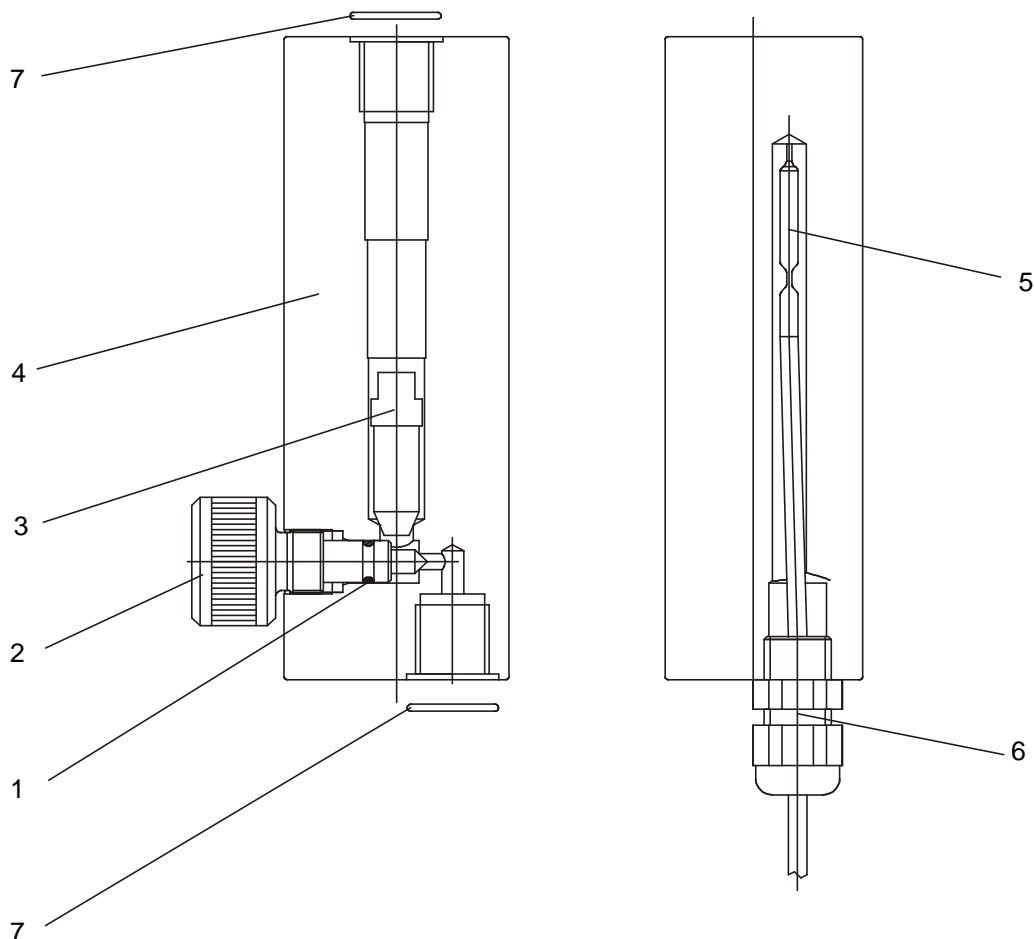

Pos.	Qty.	Designation	Order no.	Material/color/dimensions
1	1	O-ring	80618	Viton d 5 x 1.5
2	1	Adjusting screw	35332	PVDF, white
3	1	Float	35556	PVC/ permanent magnet
4	1	Flow monitor housing	35330	PMMA, transparent
5	1	Reed contact with cable	25070	Grey / black
6	1	PG -screw fixing	78232	PA, black
7	2	O-ring	80058	Viton 12x2

Keep the EASYPOOL and its components' operating instructions readily accessible.

Contents

1. General
2. Scope of delivery
3. Functional elements
4. Installation
5. Startup
6. Operation
7. Switching off
8. Maintenance
9. Troubleshooting

Note! The sampling and metering station EASYPOOL is a system consisting of several components. Therefore please also observe the technical documentation of TOPAX Pool (BW 4 50 02), of the chlorine measuring cell CS120 (BW 4 11 00), of EASYDOS peristaltic pump (MB/ET/BW 1 10 01 and 1 10 02) and of all additional measuring cells and devices.

The configuration varies depending on the application.

1. General

The sampling and metering station EASYPOOL was developed as an inexpensive unit for private or small swimming pools. It includes all components for controlling the water parameters. Only the injection points and the chemical supply system (suction line/container) have to be installed on site. EASYPOOL offers a maximum of performance with a minimum financial and space requirement.

2. Scope of delivery

Depending on the equipment you ordered with the sampling station, the scope of delivery varies regarding the accessories enclosed. Compare the scope of delivery with the delivery note when unpacking the consignment. If there are any discrepancies, try to find out the reason.

3. Functions

The following functional units are integrated on the sampling station:

- *Sampling water filter*
to protect the measuring cell against coarse dirt
- *Sampling*
for manual water sampling during calibration
- *Precision control valve*
for adjusting the water flow
- *Flow monitor*
switches off the control system in the case of lack of water
- *pH and redox measurement*
using a combination electrode

- *Temperature measurement*
using a resistance temperature sensor
- *Amperimetric chlorine measuring cell*
with electrode cleaning function
for a detailed description of the functions, please see also MB 4 11 01
- *Controller TOPAX POOL*
- *Peristaltic pump EASYDOSperistaltic*
for metering sodium hypochlorite and acids
- *Peristaltic pump EASYDOSperistaltic V*
for metering flocculation agents

4. Installation

The sampling station is mounted on the wall so that the electronic controller can easily be read and operated by the operating personnel. For fixing it to the wall, please use the screws and washers supplied. Their material and dimensions are specially adapted to this application.

4.1 Hydraulic connection

The sample water is delivered to the sampling station via plastic pipes or tubings made of PVC or PE. Don't use metal pipes under any circumstances as they could affect the measuring result because of chlorine consumption.

The sampling water has to be routed to the sampling station with the least possible **delay** to ensure effective control of the water quality. The sample water line should therefore be as short as possible with small cross sections. A line with a length of 25 meters and DN6 is sufficient to cause a delay of approx. 1 minute. This delay is increased to approx. 5 minutes if a DN15 line is used to avoid high pressure losses. Make sure that the applicable regulations are observed when **withdrawing the sample water**. DIN 19643 for example prescribes that the water in swimming pools has to be withdrawn directly from the pool in order to avoid measurement errors caused by chlorine consumption in the overflow. When withdrawing water from the piping system make sure that the sample is withdrawn from the middle of the line.

In many cases the installation of a **80µm prefilter** is useful, particularly in the case of open-air swimming pools from which the sample water is withdrawn directly from the pool. Without such a filter, blossoms and leaves in the pool water for example could clog the dirt trap in the acrylic block (cf. installation diagram in MB 2 37 17). The inserts of the dirt trap and the 80µm filter have to be cleaned or exchanged at regular intervals so that the measured value is not affected by chlorine consumption in these filters.

It is advisable to use a **sample water pump** if the sample water pressure is insufficient (at least 0.15 bar at the connection point of the sampling station). This also helps to avoid long delays when covering long distances between withdrawal point and sampling station.

The pump delivers the sample water over the long distance in a loop line past the sampling station and only a partial flow is used for the actual measurement. The throttle valve must never be closed completely. Otherwise very long delays will make control more difficult. Moreover, the water in the pump would heat up strongly and result in measuring errors. A pressure gauge in the loop line is useful for adjusting the throttle valve.

The sampling station EASYPOOL is pressure-proof up to 6 bar, so that the sampling water can be lead back without problems in pressure lines. However, make sure that the pressure drop is high enough and remains constant.

4.2 Electrical connection

Concerning the general electric installation the local regulations (DIN, VDE, ...) have to be observed. Electrical work must always be carried out by specialist staff!

Basically the electrical connection of EASYPOOL is limited to connecting the main plug to a power socket.

The combined pH and Redox electrodes are connected to the measuring amplifier via BNC connectors. The chlorine measuring cell and the temperature sensor are connected via series terminal strips in the electronic controller. Please also observe the operating instructions for the controller and the measuring cells.

5. Startup

5.1 Sensor mounting

The combined pH and Redox electrodes are inserted from the top along with the enclosed Pg13.5 screw couplings in the acrylic block. The temperature electrode is inserted laterally from the bottom with the smaller cable screwing (M12x1.5) and fixed to the metal protection tube.

Note:

Keep the protective caps of the glass electrodes in a safe place. They will be needed again to keep the electrodes moist and to protect them if the sampling station is put out of service.

5.2 Switching on the sample water

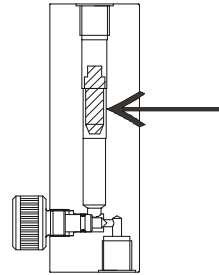

Set the needle valve at the flow control sensor to such a position that the float element floats in the center step drilling. Only in that case the integrated Reed contact closes and releases metering. This applies only for large swimming pools in which the filter flow is reduced overnight in order to save energy (admissible according to DIN19643). If there is a sufficient flow of sample water, the glass balls in the chlorine measuring cell start to rotate. If the flow is too high the float rises up to the highest step drilling and the Reed contact interrupts again. The controller switches off metering.

Only if the float is in the center position a correct measurement and a trouble-free operation are guaranteed. If the flow is too low the measuring signal will not be reliable. If the flow is too high the measuring cell will be affected and will wear out too fast.

5.3 Calibration of the measuring amplifier

The sampling water can be withdrawn using the ball valve provided for this purpose. Sample water should flow for approx. 1 hour before calibrating the measuring amplifiers since the chlorine measuring cells in particular require a certain break-in period before delivering stable measuring values. The measuring amplifiers are always calibrated in the same way regardless which model. The procedure is described in detail in the operating instructions for the measuring amplifiers and the controller respectively.

Close the two ball valves at the inlet and outlet of the sampling station before removing the electrodes. For calibrating the pH measuring amplifier two buffer solutions are required. These solutions should represent the limits of the expected measuring range (e.g. buffer solutions pH 6.8 and 9.28 for measuring values of approx. pH 7).

Note:

The pH electrode can be fitted in the holder at the front of the acrylic block during calibration.

For calibrating the Redox measuring amplifier only one buffer solution (e.g. 468mV) is required. The Redox electrode can be hooked into the holder at the front of the acrylic block during calibration.

The buffer solutions have a limited shelf life. Please observe the printed expiration date.

Residual chlorine measuring cell

Since measurement of the free effective chlorine strongly depends on pH, the chlorine measuring amplifier must not be adjusted until pH calibration is completed and stable pH values are obtained. The chlorine measuring cell has to be two-point calibrated (zero and slope), refer also to technical documentation MB 4 12 00 / 1.

6. Operation

Calibration of the measuring amplifiers should be checked once a week unless local regulations specify a shorter interval. If necessary, readjust the measuring amplifiers (see above).

The filters in the sample water feed line should be checked at the same intervals. If they are clogged they have to be cleaned or replaced in order to prevent distortion of the measuring values resulting from chlorine depletion in the filters.

7. Switching off

The water flow through the measuring cell should not be switched off if operation is only to be interrupted for a short time. Otherwise deposits would build up on the electrode surface and would first have to be removed by the rotating balls if the system is restarted. An additional break-in period would consequently have to be expected for the chlorine measuring cell. If the system is switched off for several days or e.g. for the winter, the water should be discharged and the chlorine measuring cell should be dried completely (e.g. by using compressed air). The pH, Redox and reference electrodes have to be protected from drying out. The enclosed rubber cap has to be filled with KCl solution and slipped on to the electrode bottom. The electrodes are stored in an upright position with the electrode bottom pointing downwards.

8. Maintenance

The annual maintenance consists of visually examining all components and cleaning the fittings block, if necessary, including a replacement of the seals.

The **service life of glass electrodes** depends on the service conditions and water properties (e.g. aggressiveness, greases, etc.). and normally comprises approx. 12...15 months, including 50% storage time.

Copper and platinum electrodes can have a service life of several years depending on the aggressiveness and abrasiveness of the water. They need only be replaced if severely worn (e.g. very thin points in the platinum wire). Strong deposits on the surface of the metal can be carefully removed using fine emery cloth (e.g. grading range 800).

It is important that the Reed contact only closes if the float is in the center step drilling. Above and below the center step drilling the Reed contact has to be open (with TOPAX Pool: display "ext. switching off"). If the switching function still is not perfect the Reed contact can be displaced using the binding screw.

9. Troubleshooting

Type of fault	Possible cause	Recommended action
Balls in the chlorine measuring cell rotate too slowly or float does not rise.	Water pressure too low.	Use a sample water line with a larger cross-section. IMPORTANT! Note the delay. Installation of a sample water pump (see 4.1 Hydraulic connection).
	Filter in the sample water line or fitting block fouled.	Clean or replace the filter insert.
	Needle valve clogged.	Fully open the needle valve once and re-adjust.
	Inflow nozzle of chlorine measuring cell severely fouled.	Clean nozzle (see 8. Maintenance).
Float rises, but Reed contact does not close.	Mismatch between float and Reed contact.	(see 8. Maintenance) Adjust Reed contact in clamped joint if necessary.
	Reed contact defective.	Replace Reed contact.
Reading on connected measuring amplifier fluctuates irregularly and does not correspond to the comparison measurement.	Slight leakage flows in the pumps, cause interfering voltages in the sample water.	Mount metal nuts in the pipe line before and behind the sampling station and connect them both with the protective conductor of the power supply.
	Connected devices are not electrically isolated.	Connect a potential separator at the current outputs 0(4)...20mA of the measuring amplifier.
	Particularly when measuring the residual chlorine: Unsteady pH value has a disproportionately strong effect on chlorine measurement. (With manual measurements using the DPD method, non-active chlorine in the water is also determined as a result of pH-reduction thus simulating a higher chlorine concentration).	Stabilize the pH value of the water (e.g. optimize the open loop, controller parameters). Switch on pH compensation.
Reading on the measuring amplifier for free chlorine is identical with the comparison measurement on the sampling station, but differs from the comparison measurement directly in the pool.	Chlorine depletion in the sample water line resulting from severely fouled filters or metal pipes.	Clean or replace filter inserts, use plastic pipes or tubing lines instead of metal pipes.
	Long delay resulting from long sample water line with relatively large cross-section. The water at the sampling station corresponds to that in the pool some time ago.	Reduce the delay, e.g. by using a sample water pump (see 4.1 Hydraulic connection).
Strong electrode consumption of the chlorine measuring cells	Water flow rate too high	Reduce water flow and adjust switching contact. (see 8. Maintenance)
	Operation with salt water without having adapted the electrodes.	Replace copper electrode by silver electrode. (Use additional O-ring.)